

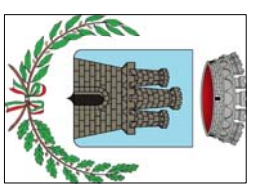

COMUNE DI FELITTO



COMUNE DI ROCCASPIDE



COMUNE DI CASTEL SAN LORENZO

OGGETTO:
Progetto di Adeguamento e Messa in Sicurezza Strada Intercomunale Scalielle - Pazzano - Fontana Laurenti - Acquarilello - Carpiolle nei Comuni di Felitto - Castel San Lorenzo - Roccaaspide

PROGETTO DEFINITIVO

Proq. n°:

Maggio 2021

Comittente:
Comune di Felitto

Descrizione Laboratorio:
**Elaborati Grafici:
- Particolari Costruttivi, Barriera
- Protezione Bordo Laterale H2**

Tavola n°:
25

Scala:
VARIE

Responsabile del procedimento
Ing Daniele Grazzo

Progettista
Ing Tommaso Maria Giuliani

Documento di proprietà dell'intercomunale
Comune di Felitto

Opini valide a numero di foggi

H2 Bordo Laterale CLASSE H2 BORDO LATERALE W6



ACCIAIO	COBRI EN 300m 3x3x1m
CERTIFICAZIONE	CE
LARGHEZZA DI FUNZIONAMENTO	W6
ALTEZZA PUNTO TERRA	90cm
PROFONDITA' DI INNESSIONE	70cm
INCOMBIO TRASVERSALE	300cm
INTEGERSIEMPLE	300cm
ESISTENZE BARRETTA ESIGIA	21 mt invariati Includi
DIMENSIONI BACO	C 150 x 150 x 50 x 5 (sp. 10mm)

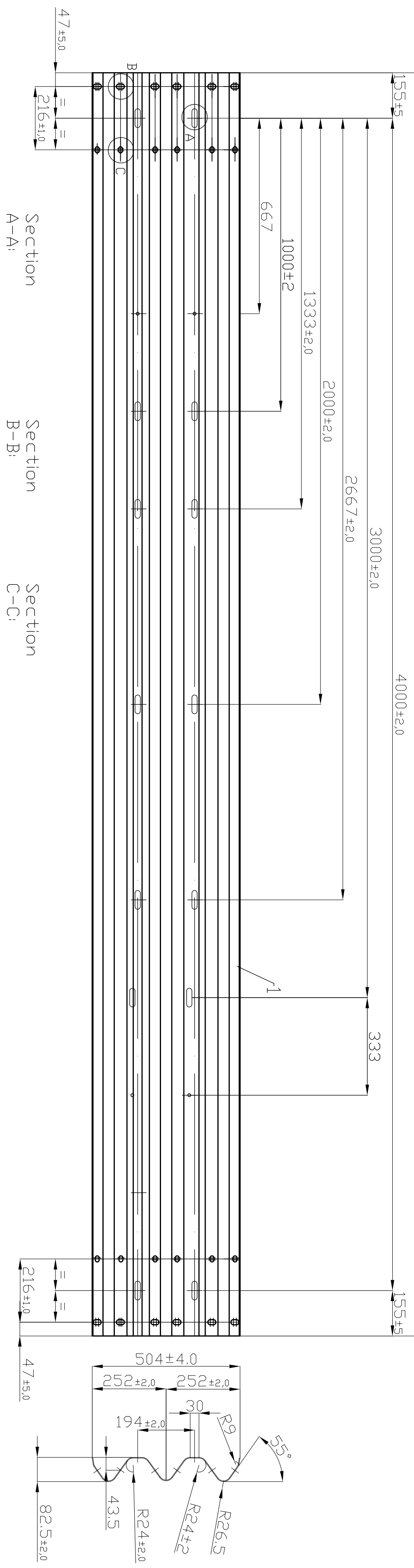
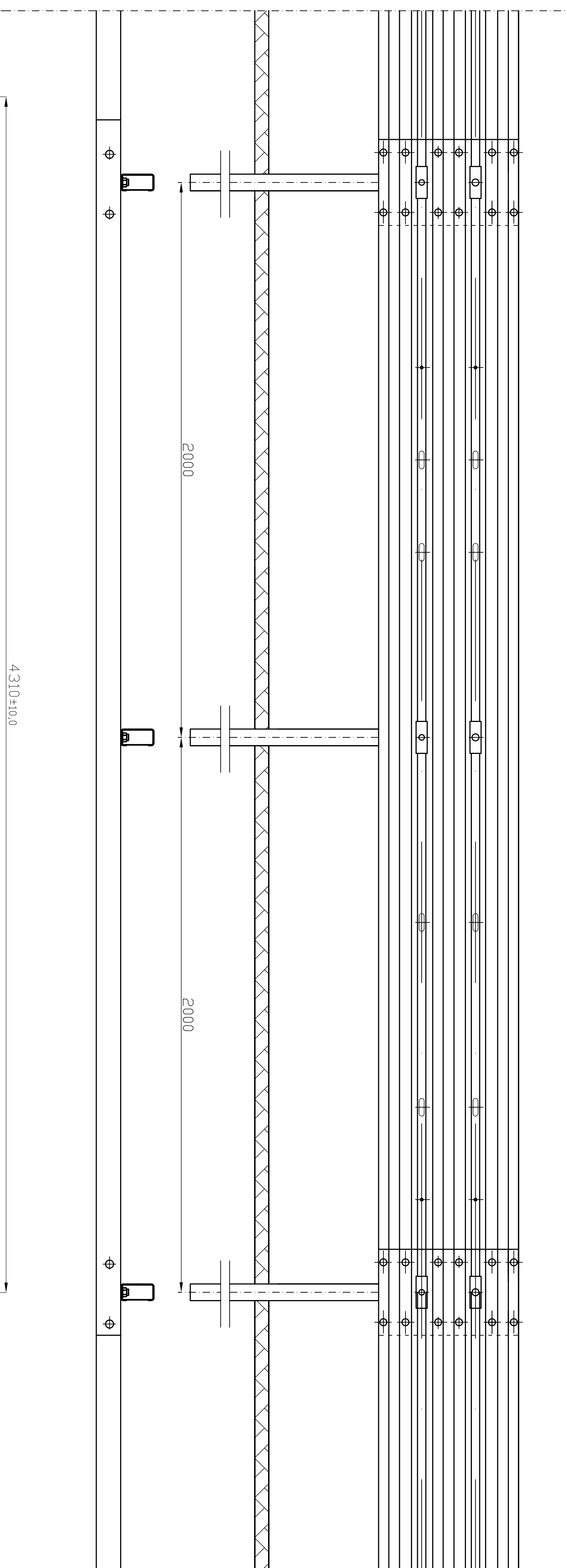

Technical requirements:
 1) Nominal thickness of steel $\delta = 2.5 \pm 0.17$
 2) Coating - hot dip zinc galvanizing, according to EN 1461:2009

Fish plate thickness 5mm \pm 0.5mm

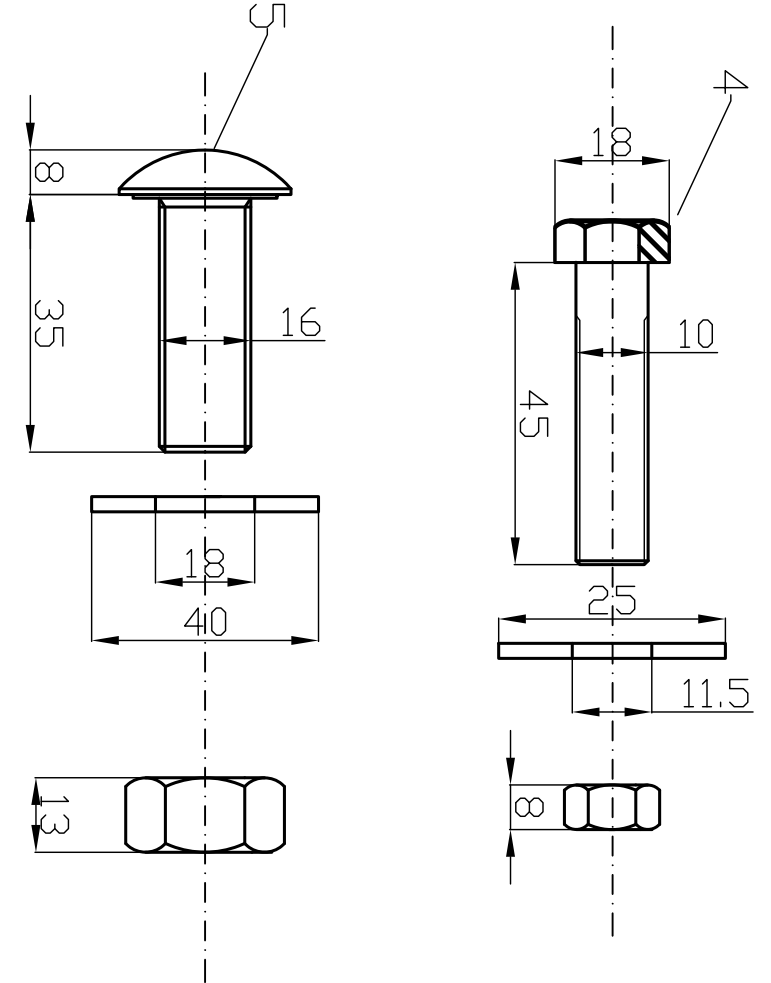
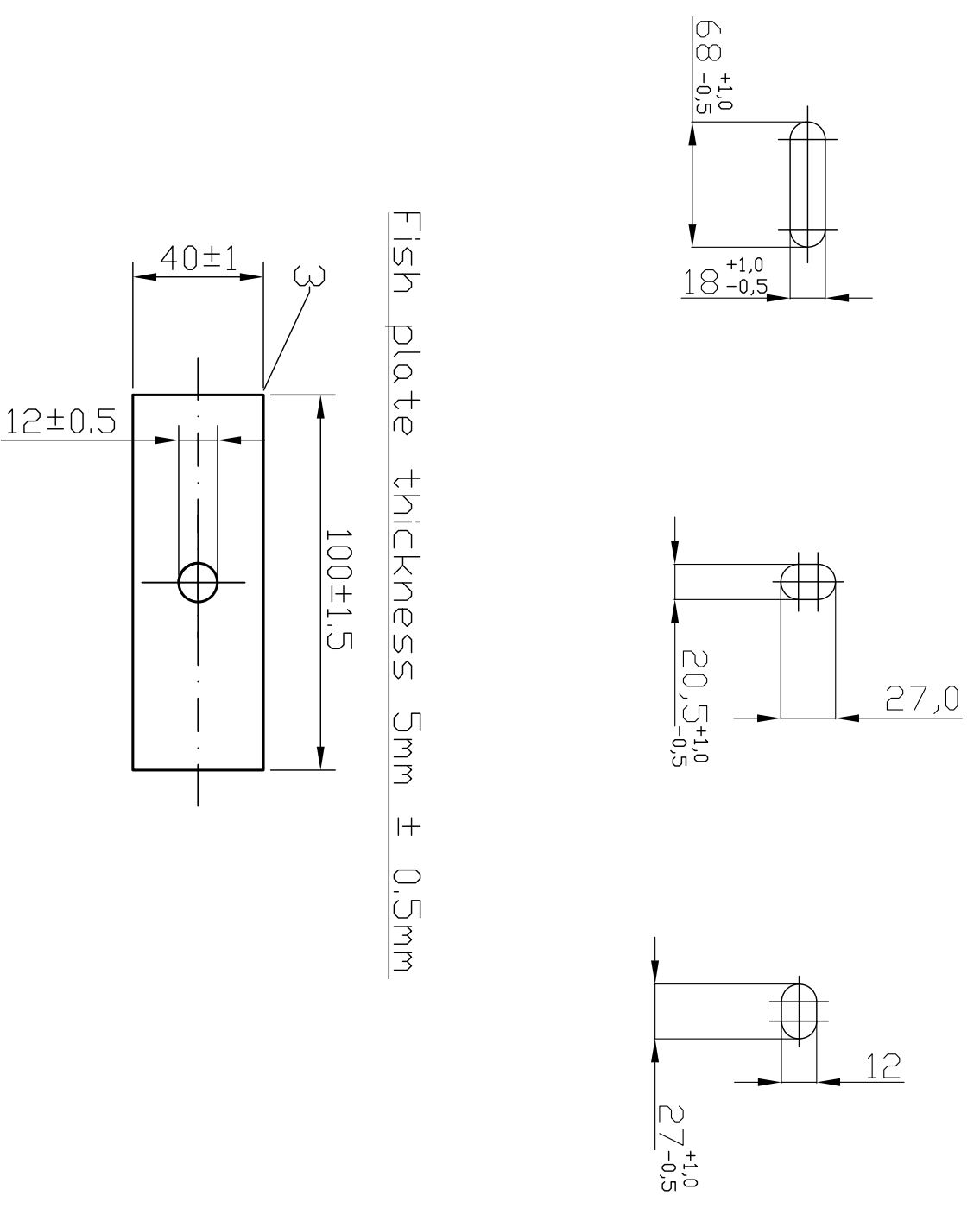

Part No.	Quantity	Description	Dimension	Weight	Material /	Norm	Coating
1	12	Beam Type A with three beams	4310	6239	S235JR	EN 10025-2/EN 1461	Z1
2	24	Cross-Beam	1630x43	72310	S235JR	EN 10025-2/EN 1461	Z1
3	96	Post	900	15215	S235JR	EN 10025-2/EN 1461	Z1
4	4	Post-top with nut, with nut	M16x45	634	S30	EN 15013	S2
5	144	Post-top with nut, with nut	M16x45	637	S30	EN 15013	S2
6	48	Washer	M20x11x4	626	S235JR	EN 15013	S2
7	144	Washer	M16x16x4	626	S235JR	EN 15013	S2

Weight of the construction: 62023 kg
 Weight of the construction: 22561 kg
 48 m

Surface	Material	3355 J2V
Remarks		
Scale	Document	
Sheet	Page	
Date of Issue	Date of Approval	
Author	Project Manager	
Drawn	Checked	
Reviewed	Approved	
Scale	Document	
Sheet	Page	
Date of Issue	Date of Approval	
Author	Project Manager	
Drawn	Checked	
Reviewed	Approved	